



## Repair Manual

### EN ORIGINAL INSTRUCTIONS

**IMPORTANT** - These instructions are for your safety.  
Please read through them thoroughly prior to handling  
the product and retain them for future reference.



5063022638182

5063022637246

5063022637369

# Contents

---

<b>1. Repairer Disclaimer</b> .....	3
<b>2. About the Product</b> .....	4
2.1 Exploded Drawing .....	4
2.2 Spare Parts Requirements Table .....	5
<b>3. Wiring and Connection Diagrams</b> .....	6
<b>4. Key Parts Locations</b> .....	7
<b>5. You Will Need</b> .....	8
<b>6. Repair Guidelines</b> .....	8
6.1 Blade Assembly .....	8
6.2 Motor Assembly .....	10
6.3 Battery Compartment .....	12
6.4 Switch Box .....	14
6.5 Control Cord .....	16
6.6 Battery Pack & Safety Key .....	18
6.7 Handlebar Assembly .....	19
6.8 Grass Box Assembly .....	20
6.9 Wheel Sets .....	21
6.10 Cutting Height Adjustment Lever .....	22
6.11 Drive gears assembly.....	23
<b>7. Fault Trouble Shooting</b> .....	23
<b>8. Technical Bulletins</b> .....	24

# 1. Repairer Disclaimer



**IMPORTANT:** Certain repairs require professional personnel and equipment. Non user-repairable components as below table should be carried out by professional repairers only. Any unauthorized attempt to repair these components may invalidate the warranty. For help with the repair or maintenance of your product, please go to the reception desk of your store, with your receipt.



**WARNING:** Unauthorized servicing may be hazardous. Consult the manual before attempting self-repair.

Item	User-Repairable	Instructions
Battery fails to charge/rapid power drain/bulging/poor contact, etc.	No	Batteries are high-risk items. Never open it yourself - contact the store or authorized service provider for repair
PCB damage/breaks/burn marks, etc.	No	Must contact store or authorized service provider
Charger failure to charge, etc.	No	Must contact store or authorized service provider
Motor burnout/replacement, etc.	No	Must contact store or authorized service provider
Wire replacement	No	Must contact store or authorized service provider
Blade assembly	Yes	Refer to the manual for details
Motor assembly	Yes	Refer to the manual for details
Battery compartment	Yes	Refer to the manual for details
Switch box	Yes	Refer to the manual for details
Control cord	Yes	Refer to the manual for details
Battery pack & safety key	Yes	Refer to the manual for details
Handlebar assembly	Yes	Refer to the manual for details
Grass box assembly	Yes	Refer to the manual for details
Wheel sets	Yes	Refer to the manual for details
Cutting height adjustment lever	Yes	Refer to the manual for details
Drive gears assembly	Yes	Refer to the manual for details

## 2. About the Product

### 2.1 Exploded Drawing

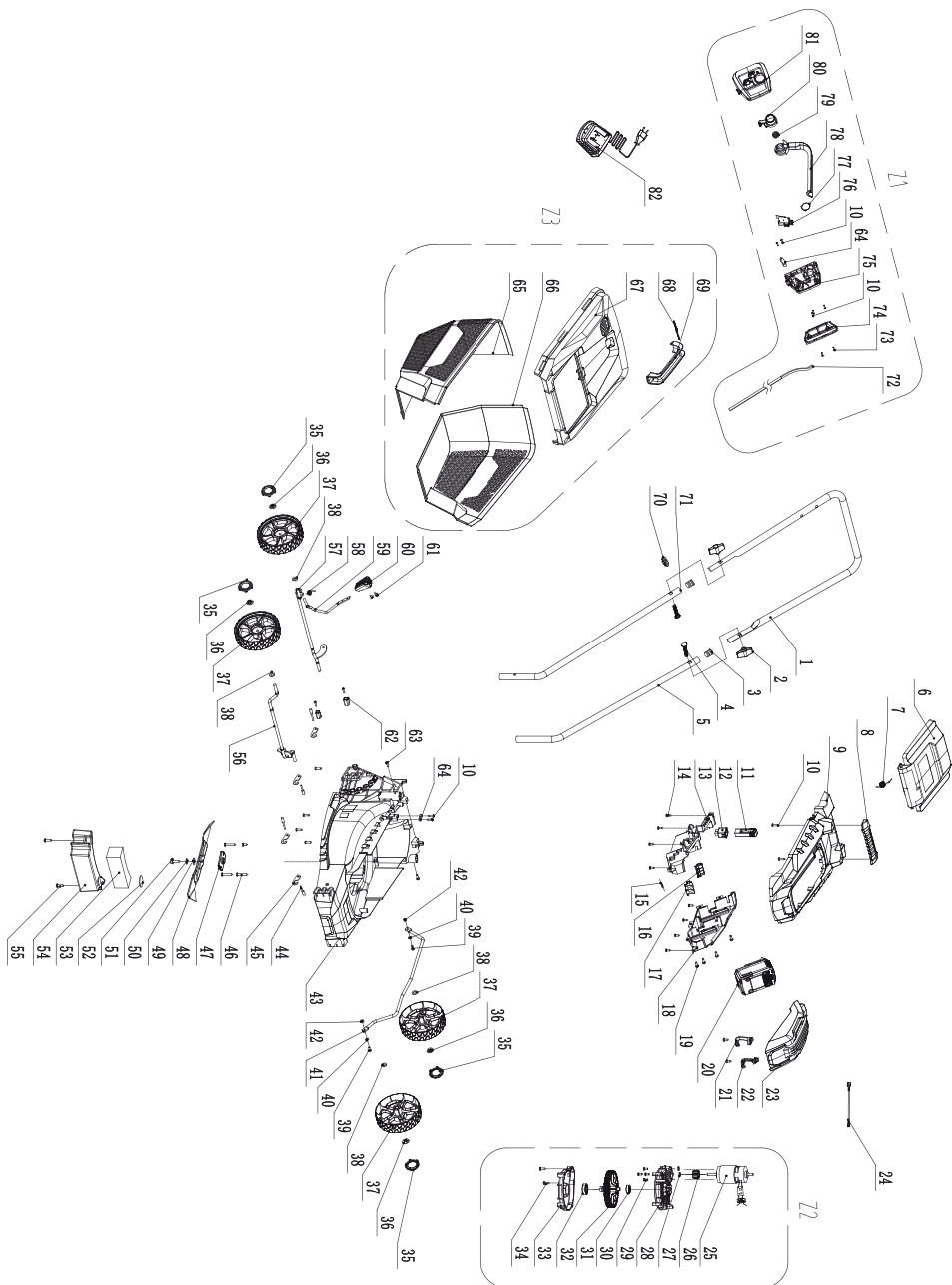

## 2.2 Spare Parts Requirements Table

Grid ID	Grid Part Name	Qty
1	Upper pole	1
2	Lock knob	2
3	Rod plug	2
4	Mounting bolt M6x40	2
5	Under pole (left)	2
6	Deflector guard	1
7	Torsion spring	1
8	Carry handle	1
9	Upper cover	1
10	Self-tapping screw ST4.2*16	16
11	Safety key	1
12	Key slot	1
13	Battery compartment (right)	1
14	Self-tapping screw ST4.2*13	11
15	Resistor 10K	1
16	Battery socket	1
17	Stopper	1
18	Battery compartment (left)	1
19	Self-tapping screw ST4.2*9.5	4
20	Battery pack (P brand)	1
21	Support ear (right)	1
22	Support ear (left)	1
23	Transparent cover	1
24	Lead wire (Green)	1
25	20V brushed motor	1
26	Small gear	1
27	Flat washer M6	2
28	Upper gear cover	1
29	Cross pan head screw M5*10	4
30	Bearing 609-2Z	1
31	Big gear	1
32	Bearing 6002-2RS	1
33	Under gear cover	1
34	Cross pan head screw M4.8*18	2
35	Wheel cap	4
36	Retaining washer	4
37	Wheel	4
38	Flat washer M8	4
39	Bolt M5	2
40	Wave washer	2

Grid ID	Grid Part Name	Qty
41	Adjustment lever	1
42	Nut M5	2
43	Bottom cover	1
44	Blind rivet M4*13	4
45	Wheel lever	4
46	Self-tapping screw ST4.8*35	3
47	Blade holder	1
48	Cutting blade	1
49	Flat washer M8	1
50	Spring washer M8	1
51	Mounting bolt M8*20	1
52	Spong	1
53	Sanding bag	1
54	Front cover	1
55	Self-tapping washer screw assembly	2
56	Front axle assembly	1
57	Back axle assembly	1
58	Spring for cutting height adjustment	1
59	Cutting height adjustment lever	1
60	Knob for cutting height adjustment	1
61	Cross pan head screw M4.8*10	2
62	Stopper for cutting height adjustment	2
63	Self-tapping screw assembly ST4.2*16	2
64	Press plate for control cord	2
65	Grass box part (right)	1
66	Grass box part (left)	1
67	Top cover for grass box	1
68	Hatch	1
69	Carry handle for grass box	1
70	Cord clip	1
71	Under pole (right)	1
72	Control cord	1
73	Self-tapping screw M4.2*19	2
74	Fixed switch cover	1
75	Under switch cover	1
76	Switch	1
77	Spring for switch	1
78	Start lever	1
79	Spring for start lever	1
80	Switch button	1
81	Upper switch cover	1
82	Fast charger (P brand)	1

### 3. Wiring and Connection Diagrams

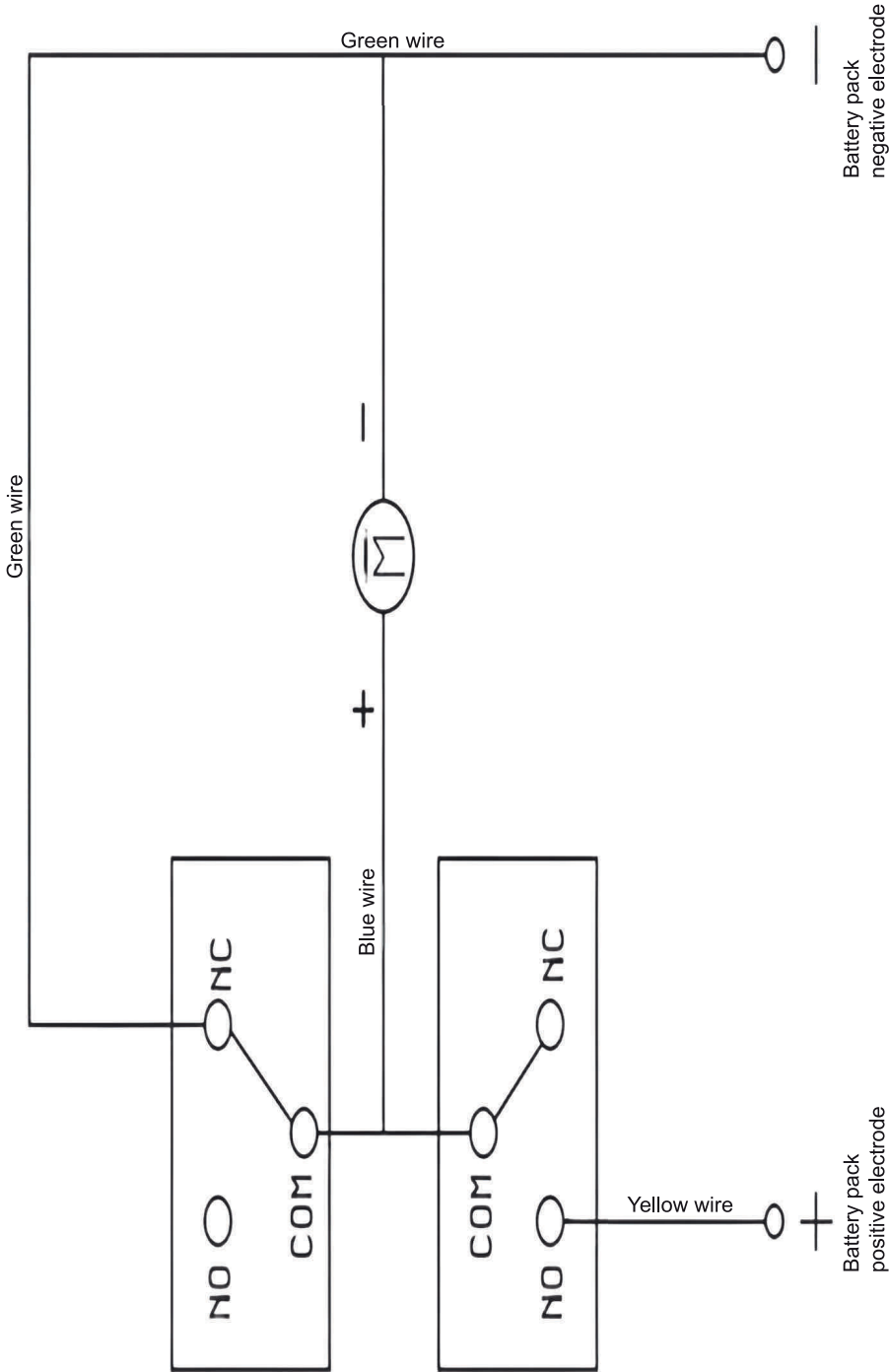

## 4. Key Parts Locations



Grid ID	Grid Part Name
1	Upper pole
5	Under pole (left)
11	Safety key
13	Battery compartment (right)

Grid ID	Grid Part Name
48	Cutting blade
51	Mounting bolt
58	Spring for cutting height adjustment
59	Cutting height adjustment lever

Grid ID	Grid Part Name
18	Battery compartment (left)
20	Battery pack
21	Support ear (right)
22	Support ear (left)
23	Transparent cover
25	20V brushed motor
37	Wheel

Grid ID	Grid Part Name
65	Grass box part (right)
66	Grass box part (left)
67	Top cover for grass box
76	Switch
71	Under pole (right)
72	Control cord

## 5. You Will Need

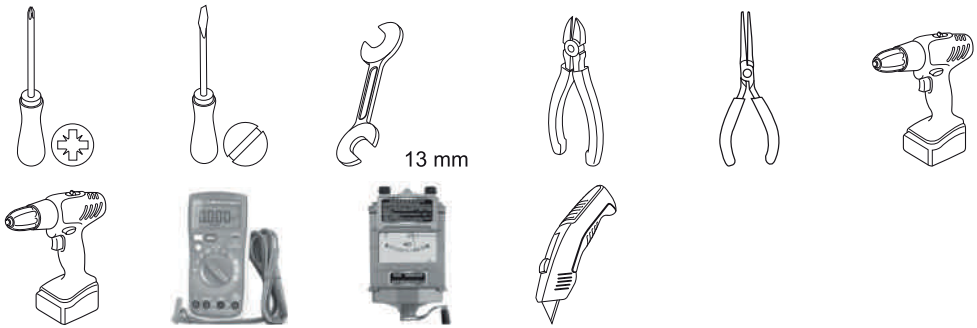

## 6. Repair Guidelines

### 6.1 Blade Assembly

#### Tools, repair and test equipment

- 13mm socket and wrench
- Philips #2 Screwdriver

**Time required** - 15 Minutes

#### Spare Parts

- Cutting blade (48)
- Mounting bolt (51)

#### When to replace the cutting blade

- **Severe wear:** The blade edge becomes dull and the thickness noticeably decreases.
- **Gap or crack:** The edge of the blade may have a gap, crack, or fracture, which may be caused by impact with hard objects such as stones or metal.
- **Deformation and bending:** The blade is bent or twisted, causing it to lose balance during rotation and causing severe vibration of the machine body.
- **Severe rusting:** Long term exposure to humid environments can cause rusting, affecting strength or cutting efficiency.
- **Poor cutting effect:** The grass is uneven, missed, or requires multiple repeated cuts after cutting.
- **Abnormal noise/vibration:** When the blade is unbalanced or deformed, the lawn mower will make abnormal noises or obvious vibrations.
- **High rotational resistance:** When manually rotating the blade, it may get stuck or not flow smoothly, which may be caused by bearing damage or blade deformation.
- **Long using time:** 50 hours mowing or 2 years whichever is sooner regardless of condition.

## Repair Procedures:

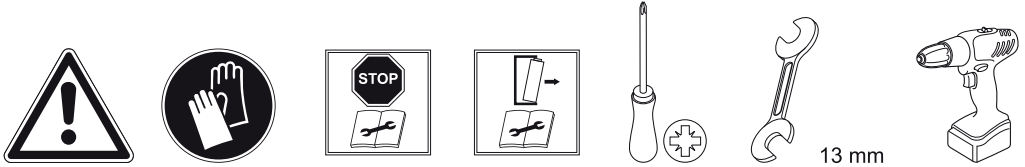

1. Open the transparent cover (23), then remove the safety key (11) and battery pack (20) (Fig. 1).
2. Loosen the mounting bolt (51) counterclockwise (Fig. 2) using a suitable electric impact wrench (socket size 13 mm), remove it together with the spring washer (50), the flat washer (49) and the cutting blade (48).

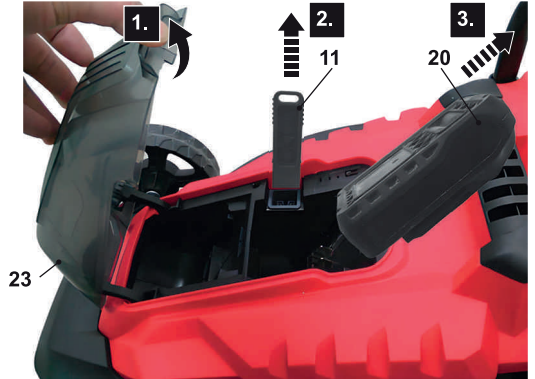

Fig. 1

**NOTE:** If a hand tool wrench or spanner is used instead of an electric impact wrench, the cutting blade (48) should be prevented from rotating while loosening the bolt. Wear heavy-duty gloves and grip the blade firmly. Use a good-size piece of wood to block the rotation of the blade if necessary.

3. Replace the cutting blade (48) with a new one of the same type. Check the status of blade holder (47) onto the spindle firstly, then attach the cutting blade (48) to the blade holder (47) by aligning it with the patterns on the blade holder (47), fix the assembly with the flat washer (49), the spring washer (50) and the mounting bolt (51), and pre-tighten the blade assembly by hand.
4. Hold the cutting blade (48) firmly with a heavy-duty gloved hand and/or a wood stick, tighten the mounting bolt (51) clockwise with 25 Nm min, 30 Nm max to ensure safe operation of your machine (Fig. 3).



Fig. 2

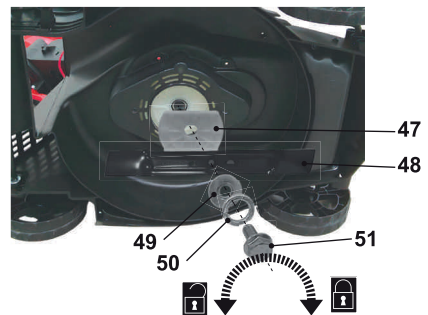

Fig. 3



**WARNING:** Before each use, make sure that the cutting blade (51) and all the fixing parts are installed correctly and tightened securely.

Only use original spare mounting blot (51) for replacement.



**NOTE:** Lubricate the cutting blade (51) after each use to prolong the life span of cutting blade (51) and machine.

Apply light machine oil along the edge of the cutting blade (51).

## 6.2 Motor Assembly

### Tools, repair and test equipment

- Philips #2 Screwdriver
- Nose plier
- Multimeter
- Megohmmeter

### Spare Parts

- 20V brushed motor (25)

**Time required** - 15 Minutes

### When to replace the motor assembly:

- **The motor does not rotate:** There is no response after being powered on, which may be caused by winding burnout, brush wear, or internal circuit breakage.
- **Insufficient power:** The lawn mower's speed has significantly decreased, making it unable to cut properly. This may be due to a short circuit in the coil, poor contact of the carbon brush, or stuck bearings.
- **Abnormal noise or vibration:** When the internal bearings are damaged, the rotor is eccentric, or the coil is broken, the motor runs with sharp friction sounds or strong vibrations.
- **Overheating or smoking:** In a short period of time, the motor casing becomes hot (over 60 °C) or has a burnt smell, usually due to overload, poor heat dissipation, or internal short circuit.
- **Severe sparks:** When the electric brush and commutator have poor contact, the sparks increase abnormally during motor operation.

### Identify other possible causes

Before determining the motor malfunction, the following issues need to be eliminated:

- **Battery issue:** Check if the battery voltage is normal (such as 18V) and ensure that there are no open circuits or poor contacts in the circuit.
- **Key issue:** There is no oxidation, corrosion, or looseness of the key contacts and the safety key is properly inserted before use.
- **Mechanical jamming:** Manually rotate the motor shaft to confirm if excessive resistance is caused by blade jamming or gearbox failure.

### Key detection steps:

- **Resistance test:** Disconnect the motor power supply and measure the resistance of the motor input terminal with a multimeter: Normal value: several ohms to tens of ohms. If the resistance is infinite (open circuit) or close to zero (short circuit), the motor needs to be replaced.
- **No load test:** Remove the blade, power on the motor separately and observe if it runs smoothly without any abnormal noise.
- **Input resistance check:** Measure the input resistance between the motor winding and the casing with a megohmmeter. If it is lower than 1MΩ, it indicates insulation aging and leakage.

### Repair Procedures:

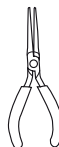
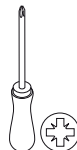
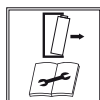

1. Remove the blade assembly as instructed in the section "Blade Assembly-> step 1 to 2".
2. Turn the machine upside down, then remove the 5 self-tapping screws ST4.2\*16 (10) using a Philips #2 screwdriver (Fig. 4).

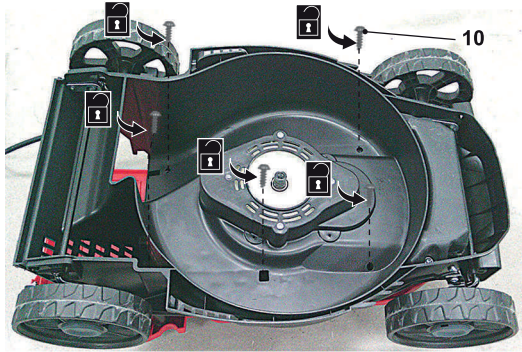

Fig. 4

3. Turn the machine back, then lift and remove the upper cover (9).
4. Separate the two connectors by a suitable nose plier (Fig. 5) as marked in red circle and the corresponding wiring system:
  - **Red** lead wire of 20V brushed motor (25) - **Blue** wire of control cord (72)
  - **Black** lead wire of 20V brushed motor (25) – **Green** wire of control cord (72)

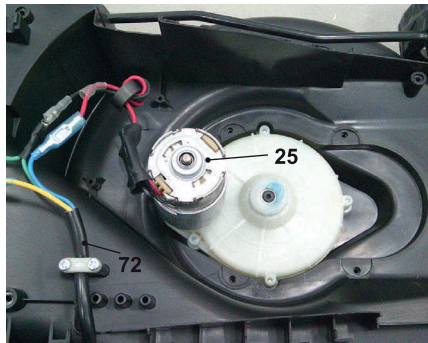

Fig. 5

5. Turn the machine over to the side, then remove the 3 self-tapping screws ST4.8\*35 (46) and 1 self-tapping screw ST4.2\*13 (14) (Fig. 6).

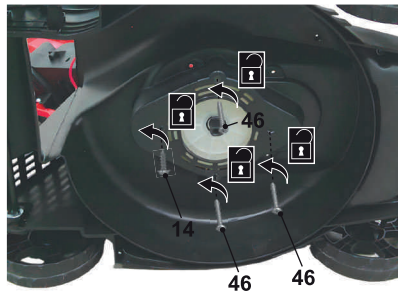

Fig. 6

6. Remove the damaged brushed 20V brushed motor (25) and replace it with a new one of the same type. Place the motor assembly correctly into two slots of bottom cover (43), then fix the motor assembly and connect the lead wires to the control cord (72) following the corresponding wiring system:
  - **Red** lead wire of 20V brushed motor (25) - **Blue** wire of control cord (72)
  - **Black** lead wire of 20V brushed motor (25) - **Green** wire of control cord (72)

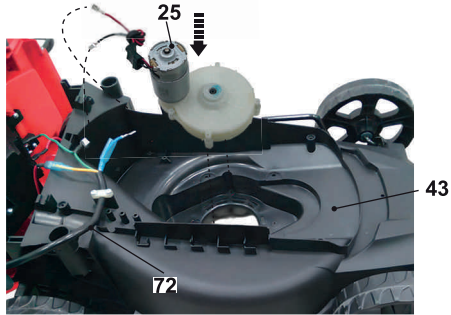

Fig. 7

7. Fit the upper cover (9) and deflector guard (6) on the bottom cover (43). Ensure that the torsion spring (7) is properly assembled before securing the connection (Fig. 8).



Fig. 8

8. Re-assemble the blade assembly before use.

### 6.3 Battery Compartment

#### Tools, repair and test equipment

- Philips #2 Screwdriver
- Nose plier

**Time required** - 15 Minutes

#### Spare Parts

- Battery compartment (13, 18)
- Support ear (21, 22)
- Transparent cover (23)

#### When to replace the battery compartment:

- **Physical damage:** The transparent cover is cracked; the support ear of the transparent cover is damaged.
- **Poor contact of battery socket:** Oxidation, corrosion, or looseness of battery socket can lead to poor contact of the connection terminals of the battery compartment.

## Repair Procedures:

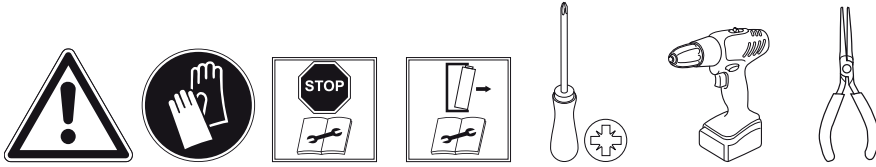

1. Remove the blade assembly as instructed in the section "Blade Assembly-> step 1 to 2".
2. Separate the two connectors by a suitable nose plier (Fig. 9) as marking in red circle and the corresponding wiring system:
  - a) **Terminal** of battery compartment (right) (13) – **Green** lead wire (24) for battery compartment
  - b) **Red** lead wire of battery compartment (left) (18) – **Yellow** wire of control cord (72)

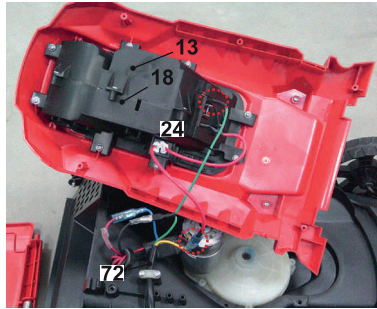

Fig. 9

3. Remove the 8 self-tapping screws ST4.2\*13 (14) using a Philips #2 screwdriver (Fig. 10).

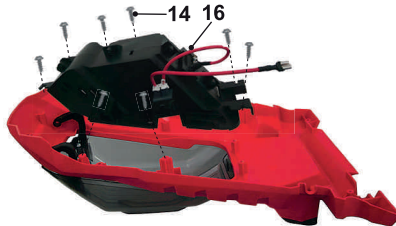

Fig. 10

4. Remove the battery compartment assembly and then replace it with a new one of the same type.
5. If necessary, squeeze the two support ears (21, 22), and then remove the transparent cover (23) (Fig. 11). Change a new one with the same type.

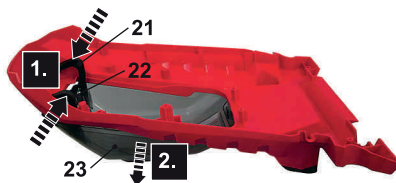

Fig. 11

- If necessary, remove the two self-tapping screw ST4.2\*13 (14) to exchange two support ears (21, 22) or transparent cover (23) (Fig. 12) with the same type.

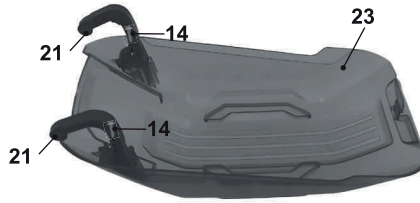
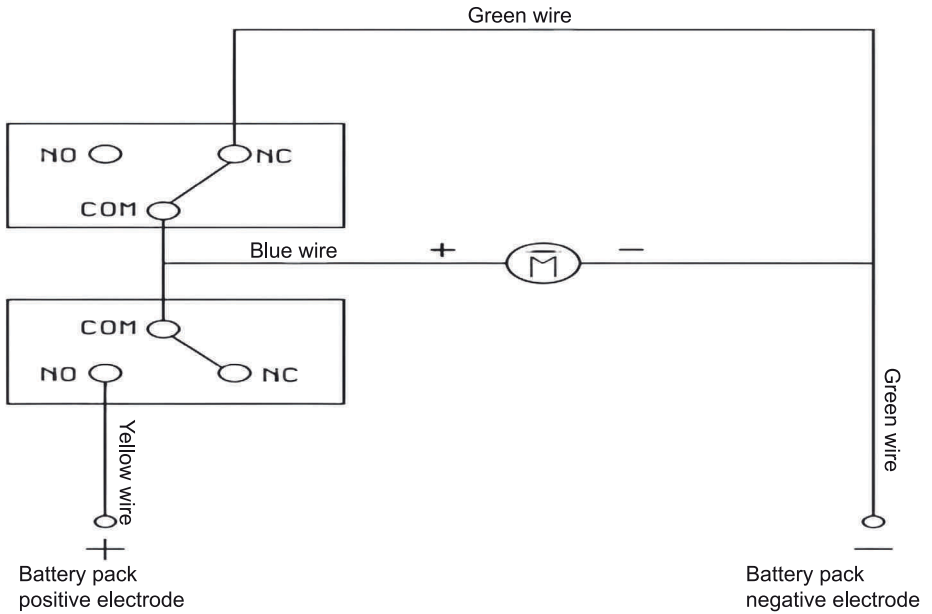

Fig. 12

- Re-assemble the battery compartment onto the upper cover (9).
- Fit the upper cover (9) and deflector guard (6) on the bottom cover (43). Ensure that the torsion spring (7) is properly assembled before securing the connection.
- Re-assemble the blade assembly before use.

**Electric circuit diagram of battery compartment:**



**6.4 Switch Box**

**Tools, repair and test equipment**

- Philips #2 Screwdriver
- Nose plier
- Multimeter

**Time required** - 15 Minutes

**Spare Parts**

- Switch (76)

## When to replace the switch box:

- **Malfunction of switch:** The lawn mower doesn't respond after being properly operated on the switch button.
- **Intermittent work:** Sudden power outage during operation, restored after lightly tapping the switch box (poor contact).
- **Overheating or burning of switch:** The switch box shell is hot, has a burnt smell or visible burn marks.

## Identify other possible causes:

Before determining the switch box malfunction, the following issues need to be eliminated:

- **Battery issue:** Check if the battery voltage is normal (such as 18V) and ensure that there are no open circuits or poor contacts in the circuit.
- **Safety key issue:** There is no oxidation, corrosion, or looseness of the key contacts and the safety key is properly inserted before use.

## Key detection steps:

- **Visual check:** Check if the leads or terminals are loose, and if there are signs of burning at the terminal connections.
- **Switch contact:** Press the switch button and measure whether the input and output terminals are conductive by a multimeter.

## Repair Procedures:

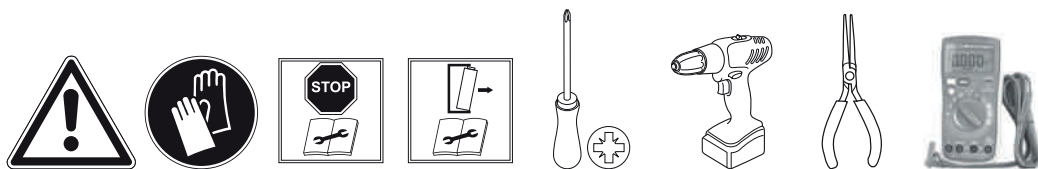

1. Remove the 3 self-tapping screws ST4.2\*16 (10) and 2 self-tapping screws (73) using a Philips #2 screwdriver (Fig. 13) and open the switch box.

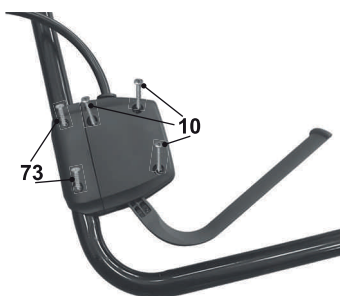

Fig. 13

2. Separate the three connectors from the terminals of the switch (76) by a suitable nose plier (Fig. 14) and the corresponding wiring system:
  - **Green** lead wire of control cord (72) – **NC** terminal of switch (76)
  - **Yellow** lead wire of control cord (72) – **NO** terminal of switch (76)
  - **Blue** lead wire of control cord (72) – **COM** terminal of switch (76)

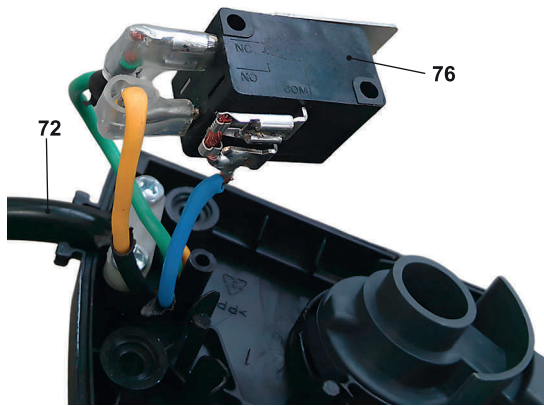
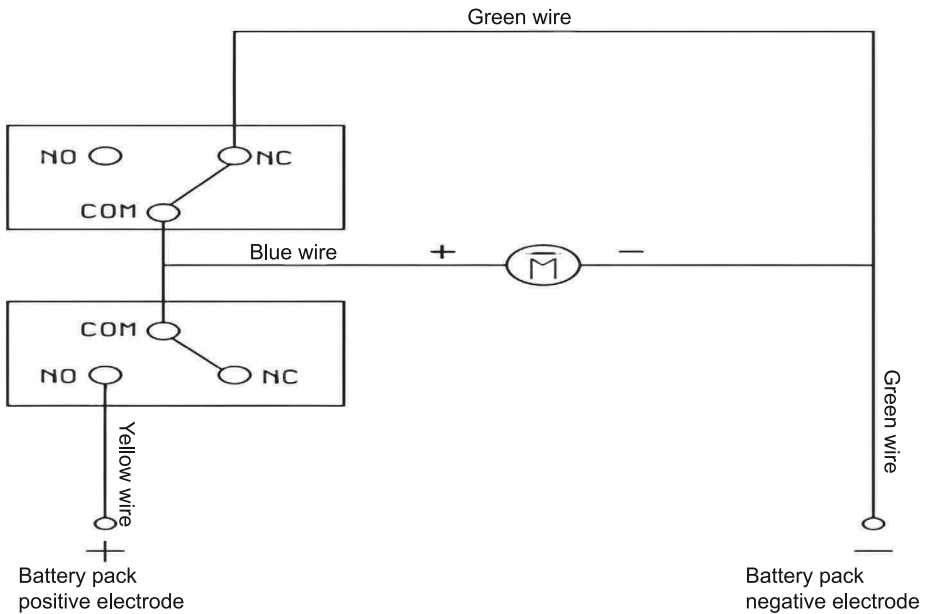

Fig. 14

3. Replace the switch with a new one of the same type.
4. Refit the switch cover and re-assembly the switch box.

**Electric circuit diagram of switch:**



**6.5 Control Cord**

**Tools, repair and test equipment**

- Philips #2 Screwdriver
- Nose plier
- Multimeter

**Time required** - 25 Minutes

**Spare Parts**

- Control cord (72)

## When to replace the control cord:

- **Visible physical damage:** Check whether naked, crushing deformation or rodent bite marks on the control cord.
- **Abnormal heating or burnt smell:** Overheating of the cable, melting of the insulation layer, and even smoking (caused by overload or short circuit).

## Repair Procedures:

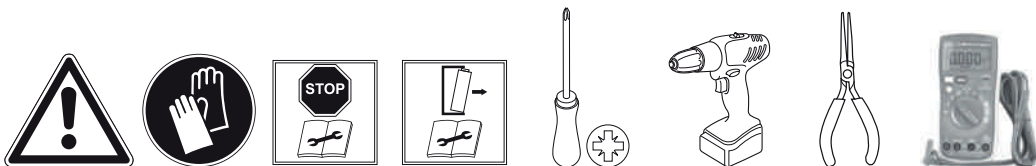

1. Remove the blade assembly as instructed in the section "Blade Assembly-> step 1 to 2".
2. Remove the upper cover (9), then separate the control cord (72) as instructed in the section "Motor Assembly-> step 1 to 4" and "Battery Compartment-> step 1 to 2".
3. Open the switch box and separate the control cord (72) as instructed in the section "Switch Box-> step 1 to 2".
4. Remove the 4 self-tapping screws ST4.2\*16 (10) and the 2 press plates (64), exchange the control cord (72) with a suitable length (Fig. 15).

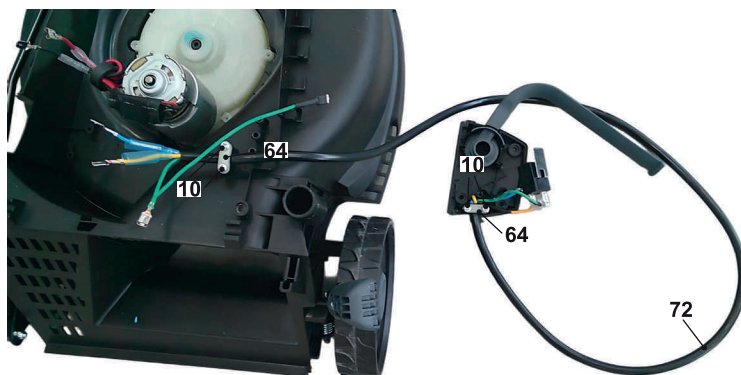
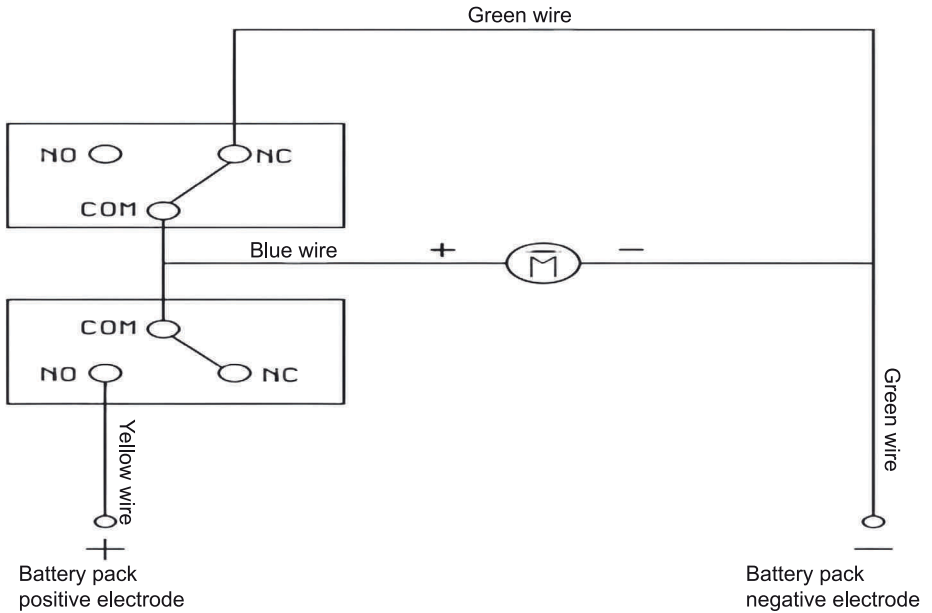

Fig. 15

5. Connect the control cord (72) with the switch (76), 20V brushed motor (25) and the battery compartment according to the wiring system in corresponding section.
6. Fix the control cord (72) properly by 4 self-tapping screws ST4.2\*16 (10) and the 2 press plates (64).
7. Re-assembly the switch box, upper cover (9), deflector guard (6) and blade assembly before use.

## Electric circuit diagram of control cord:



## 6.6 Battery Pack & Safety Key

### Tools, repair and test equipment

- None

**Time required** - 1 Minute

### Spare Parts

- Battery pack (20)

- Safety key (11)

### When to replace the battery pack / safety key

- **Visible physical damage:** Damaged battery case, corrosion sign at battery contacts
- **Voltage abnormality:** The no-load voltage is 20% lower than the nominal value (such as 18V battery pack voltage < 14V).
- **Poor contact of safety key:** Oxidation, corrosion, or looseness of safety key

### Repair Procedures:

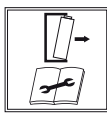

1. Open the transparent cover (23), then remove the safety key (11) and battery pack (20) (Fig. 16).

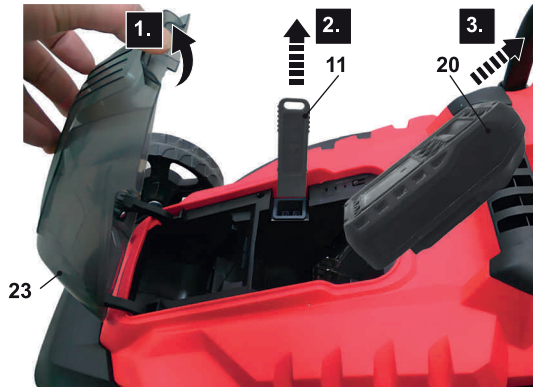

Fig. 16

2. Exchange the safety key (11) and battery pack (20) with the same type.
3. Align the battery pack (20) with the two sliding slots and slide the battery pack (20) in to attach it. Make sure that the electrical contacts are fully inserted into the battery pack (20) and that it snaps in place with a click.
4. Re-install the safety key (11) and carefully close the transparent cover (23).

## 6.7 Handlebar Assembly

### Tools, repair and test equipment

- Philips #2 Screwdriver

**Time required** - 15 Minutes

### Spare Parts

- Upper pole (1)
- Under pole (5, 71)

### When to replace the handlebar

- **Visible physical damage:** Damaged handlebar

### Repair Procedures:

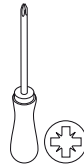
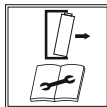

1. Pre-install the switch box on the new upper pole (1) as instructed in the section "Switch Assembly" and ready for use.
2. Put the machine on the flat and even ground.
3. Insert the under poles (5, 71) into the handle supports all the way to stop. Ensure that the mounting holes of the under poles (5, 71) and the handle supports are aligned (Fig. 17, step 1).
4. Use 2 self-tapping screw assembly ST4.2 \*16 (63) to screw into the mounting holes and fix the under poles (5, 71) with a Philips #2 Screwdriver (Fig. 17, step 2).
5. Hold the upper pole (1) with the switch button (80) facing upwards. Align the mounting holes of the upper pole (1) with the two under poles (5, 71), then pass the mounting bolt (4) through the mounting holes to the end (Fig. 17, step 3).
6. Make sure the control cord (72) run on the upper side of the under pole (71) and the upper pole (1).
7. Screw in the lock knob (2) clockwise through the thread of mounting bolt (4) on both sides and secure the connection (Fig. 17, step 4).



Fig. 17

8. Secure the control cord (72) with the cord clip (70) on the under pole (71). Pull the control cord (72) to avoid contact with the rear wheel (37) (Fig. 18).



Fig. 18

## 6.8 Grass Box Assembly

### Tools, repair and test equipment

- None

Time required - 5 Minutes

### Spare Parts

- Grass box part (65, 66)

- Top cover for grass box (67)

## When to replace the grass box

- **Visible physical damage:** Damaged grass box

### Repair Procedures:

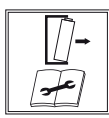

1. Discard the old grass box and re-assemble a new one.
2. Press the two parts of the grass box (65, 66) together and ensure they are properly engaged (Fig. 19, step 1).
3. Press the top cover (67) on the grass box assembly until a click sound is heard (Fig. 19, step 2). Ensure that the strip of grass box assembly is properly engaged in the groove of the top cover (67).
4. Assemble the carry handle (69) into the two assembling slots on the top cover (67), paying attention to the correct orientation (Fig. 19, steps 3, 4). Ensure that the carry handle (69) is firmly in place before use.
5. The grass box is ready for use.

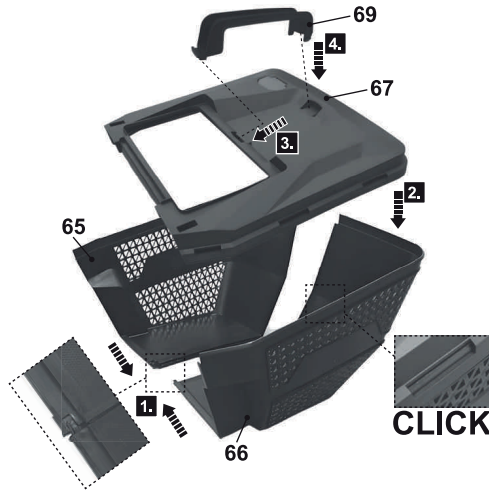

Fig. 19

## 6.9 Wheel Sets

### Tools, repair and test equipment

- Flat screwdriver
- Nose plier

**Time required** - 5 Minutes

### Spare Parts

- Wheel (37)

### When to replace the grass box

- **Visible physical damage:** Damaged wheel

### Repair Procedures:

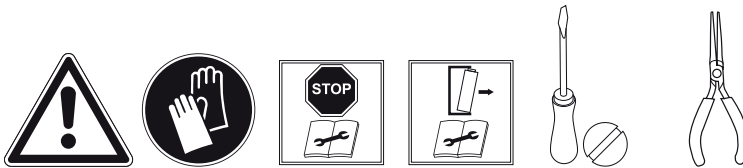

1. Remove the wheel cap (35) and the retaining washer (36) with a flat screwdriver, then remove the old wheel (37) from the wheel axle and replace the wheel (37) with a new one of the same type (Fig. 20).



Fig. 20

2. Check the status of flat washer (38) on the wheel axle firstly, then attach the wheel (37) and retaining washer (36) to the wheel axle.
3. Reattach the wheel cap (35).
4. Repeat the above exchanging steps on the other wheel (37).

## 6.10 Cutting Height Adjustment Lever

### Tools, repair and test equipment

- Flat screwdriver
- Nose plier

**Time required** - 5 Minutes

### Spare Parts

- Spring for cutting height adjustment (58)
- Cutting height adjustment lever (59)

### When to replace the grass box

- **Visible physical damage:** Damaged cutting height lever or hook
- **Malfunction of lever:** The cutting height adjustment lever can't reliably stay in position

### Repair Procedures:

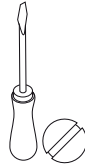
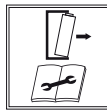

1. Remove the wheel (37) near cutting height adjustment lever (59) as instructed in the section "Wheel Sets -> step 1".
2. Detach the spring (58) from cutting height adjustment lever (59) by a nose plier (Fig. 21, step 1).
3. Remove the cutting height adjustment lever (59) and replace it with a new one of the same type (Fig. 21, step 2).

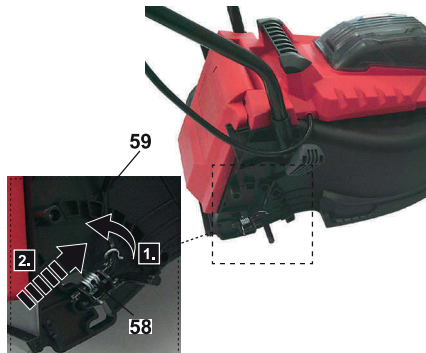
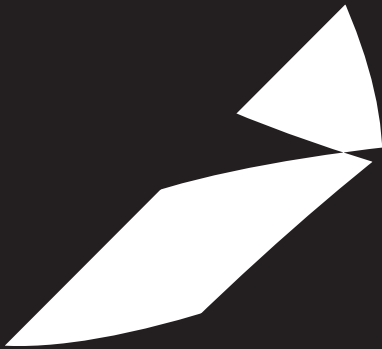

Fig. 21

1



## 8. Technical Bulletins

---

We systematically document issues identified during product use, along with corresponding solutions - including component adjustments, additions, or removals. Updated product repair instructions will be distributed to stores.



### Manufacturer

#### UK Manufacturer:

Kingfisher International Products Limited,  
1 Paddington Square, London, W2 1GG,  
United Kingdom  
[www.kingfisher.com/products](http://www.kingfisher.com/products)

### EU Manufacturer:

Kingfisher International Products B.V.  
Rapenburgerstraat 175E  
1011 VM Amsterdam  
The Netherlands  
[www.kingfisher.com/products](http://www.kingfisher.com/products)

EN [www.diy.com](http://www.diy.com)  
[www.screwfix.com](http://www.screwfix.com)  
[www.screwfix.ie](http://www.screwfix.ie)

To view instruction manuals online,  
visit [www.kingfisher.com/products](http://www.kingfisher.com/products)